

Cluster Study: Rigid Grouping Brackets vs. Independent Pan and Tilt

The objective of this study is to compare two different loudspeaker clustering concepts; a rigidly bracketed group (RG) that moves as one, and a group that is clustered with the ability for each box to be independently panned and tilted (IPT). This study is not meant to prove one is always superior, as each method has its own proper application. The goal is to show the differences, and make aware the potential pros and cons of each.

To research and provide the data/predictions included in this study the EASE program was used. EASE is a design assistance tool that allows the use of a loudspeaker manufacturer's measured data to be entered into the program. Then, based on physics and math, supply very detailed predictions of how they will interact in relation to each other, and how they will react in a given space.

The speakers for this study were chosen because they have been designed to be rigidly grouped by the manufacturer, and have manufacturer supplied brackets optional. In this study, three speakers will be used, which is fairly typical. Each box has a coverage pattern of 40 degrees horizontal and 40 degrees vertical. These same boxes will suffice in showing the difference of the clusters.

A sensitivity analysis was used to optimize both the RG and the IPT clusters. This process is simply the methodical adjustment of each of the variables to optimize its performance. Every change to each variable will be better or worse, similar to the eye doctor's exam. Once each variable has reached it's "best", and the system has reached its maximum potential, the sensitivity analysis is complete.

To begin this process, the inherent interference of every cluster can be manipulated with the use of inter-cluster delay. This doesn't eliminate the interference, but shifts it to different frequencies. The goal is to shift it out of the vocal intelligibility range.

First, in the RG cluster, the center box is delayed 2 milliseconds to "smooth" some of the interference issues. In the IPT cluster, the center box is delayed 3 milliseconds, as the spacing is different. The next step was to adjust aiming, and output levels to provide even coverage. The final results are the predictions included in this study.

Again, this study is not meant to discredit any concepts or manufacturers. It is only meant to raise awareness of the differences in concept and application.

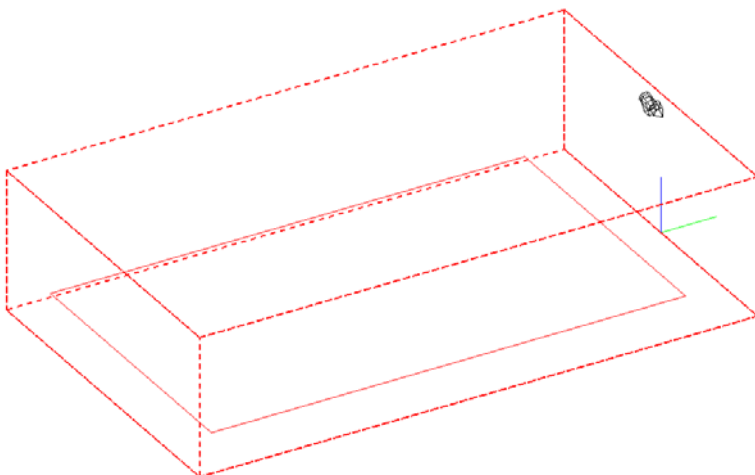

G1: Room 3D View

This is the 3D wire-frame EASE model with the dimensions of 60'(W) x 100'(L) x 25'(H)*

The listening area is set at 4' high (the average seated head height), and the speakers are set at 24' high.

The floor is commercial carpet; the ceiling and walls are gypsum. (This affects our reverb time = RT60.)

*This was an intended example of a typical space.

G2: RT-60 Curve

Here is a graph of the predicted RT-60.

It shows the length of time (sec.) that each of the audio frequencies will “hang around” (reverb).

This is crucial to the intelligibility and clarity of the intended program material.

Whenever you see a reverb time over 2 seconds, it is time to be concerned about your sound.

You will see, at our focus frequency (2000Hz), we are at about 1.6 seconds**.

**This was intended for the example effect on intelligibility.

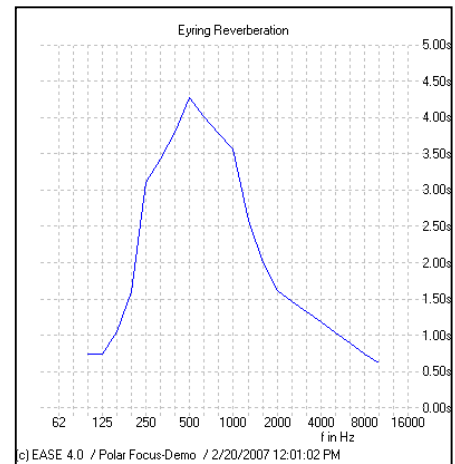

RG1: Cluster: This is a 3D representation of the *Rigid Grouping Cluster*. (RG)

IPT1: Cluster: This is a 3D representation of the *Independent Pan and Tilt Cluster*. (IPT)

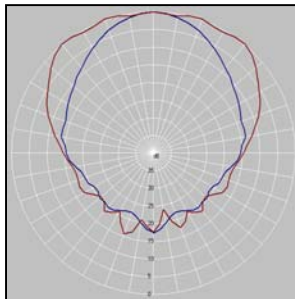
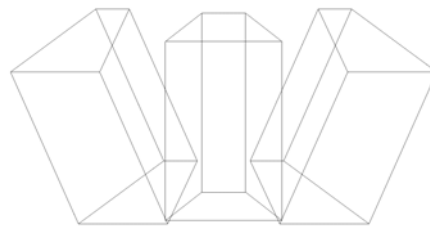
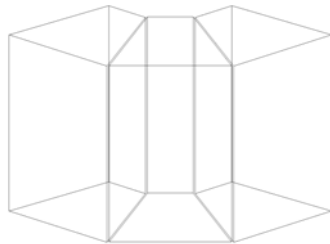

RG2: Polar 2k

This is the polar prediction of the **RG** cluster. (Red=horizontal; Blue=vertical)

You will see that the horizontal coverage is very smooth through 120 degrees.

Please note: Once the cluster is bracketed this will not change, other than the ability to aim the axis.

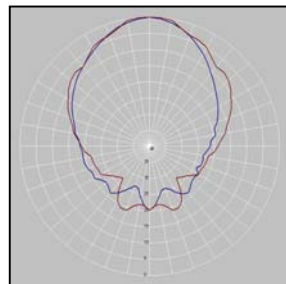

IPT2: Polar 2k

This is the polar prediction of the **IPT** cluster. (Red=horizontal; Blue=vertical)

You will see that the horizontal coverage is very smooth, but now more resembles the floor-plan.

Please note: This is only one of the multiple polar patterns available due to the independent pan and tilt.

RG3: Front view vs. **IPT3: Front view**

This is a view of the front of the clusters in the room.

Please note: There is not much difference in the look, compared to the advantages to be seen next.

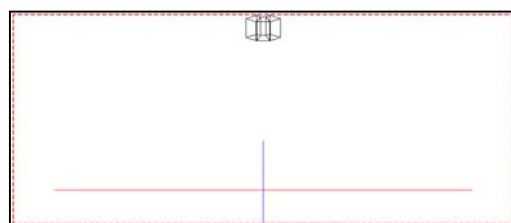

RG3: Front view

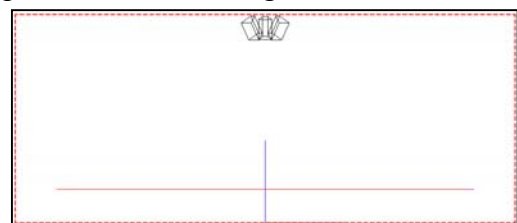

IPT3: Front view

RG4: Direct SPL 2k vs. IPT4: Direct SPL 2k

This is comparison of the direct SPL predictions at 2kHz.

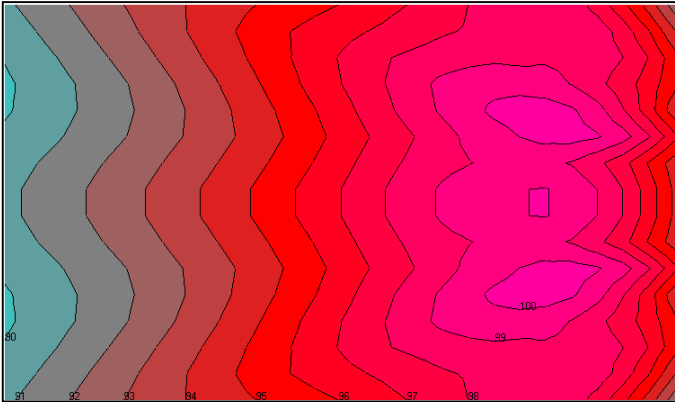

RG4: Direct SPL 2k

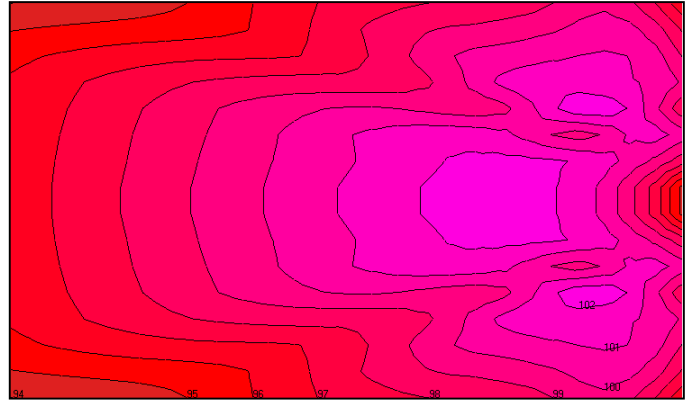

IPT4: Direct SPL 2k

RG5: Direct SPL 4k vs. IPT5: Direct SPL 4k

This is comparison of the direct SPL predictions at 4kHz.

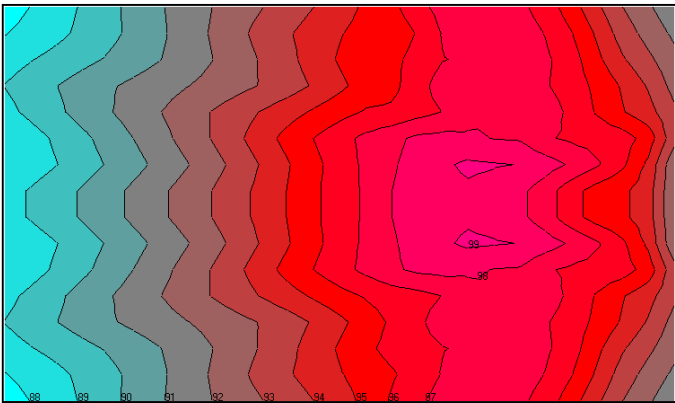

RG5: Direct SPL 4k

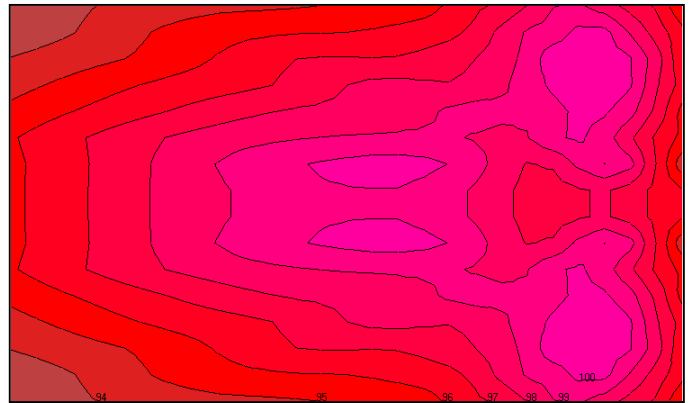

IPT5: Direct SPL 4k

RG6: Direct SPL 8k vs. IPT6: Direct SPL 8k

This is comparison of the direct SPL predictions at 8kHz.

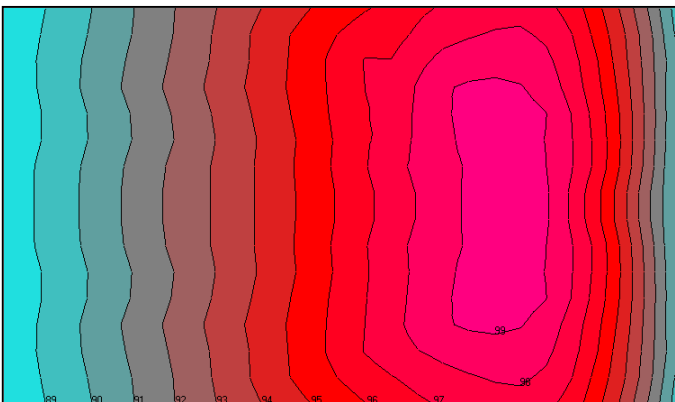

RG6: Direct SPL 8k

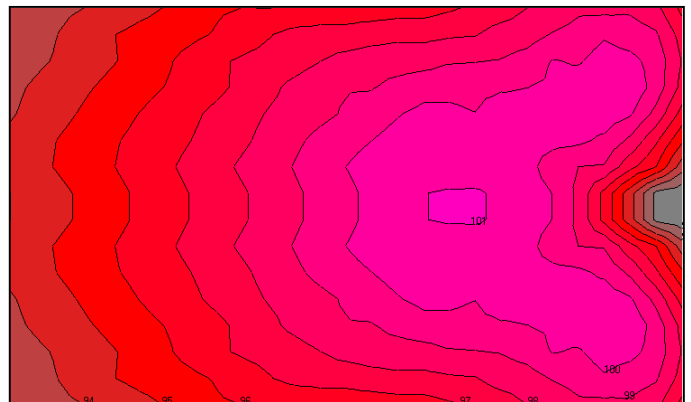

IPT6: Direct SPL 8k

From the SPL predictions:

We see there are some issues in reaching the back of the room with the **RG** cluster.

(Witnessed best in the 8 kHz plot)

We can adjust the tilt of the entire cluster, as it only moves as one unit.

However, this adjustment will also result in the loss of the front row coverage.

You will see we are fairly limited in our ability to optimize this design.

We see the issues in reaching the back of the room have been addressed by the **IPT** cluster.

We can now use the center cabinet to “throw” to the back of the room, and still adjust for the front rows.

You will see we are not limited in our ability to optimize this design.

RG7: SPL 2k 3D vs. **IPT7: SPL 2k 3D**

These 3D predictions allow us to see the amount of SPL that is hitting the sidewalls.

Please note: Although both clusters have sidewall splash, in the **RG** cluster prediction, the intensity of that energy is almost equal to the energy in the listening area. (Note the amounts of pink in each area.)

This results in a higher reverberant to direct energy ratio.

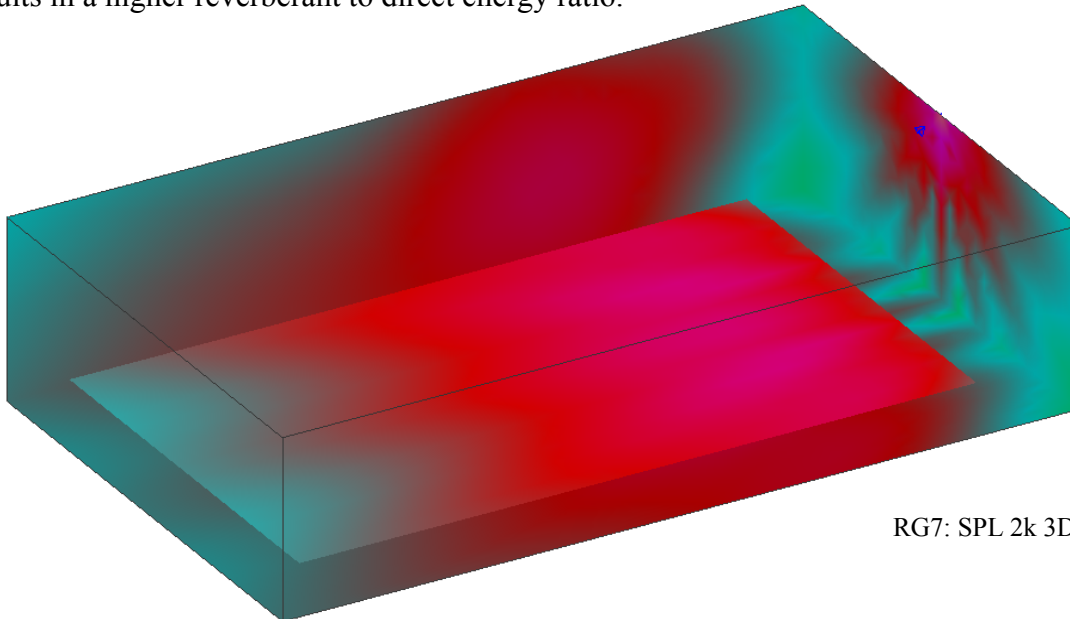

RG7: SPL 2k 3D

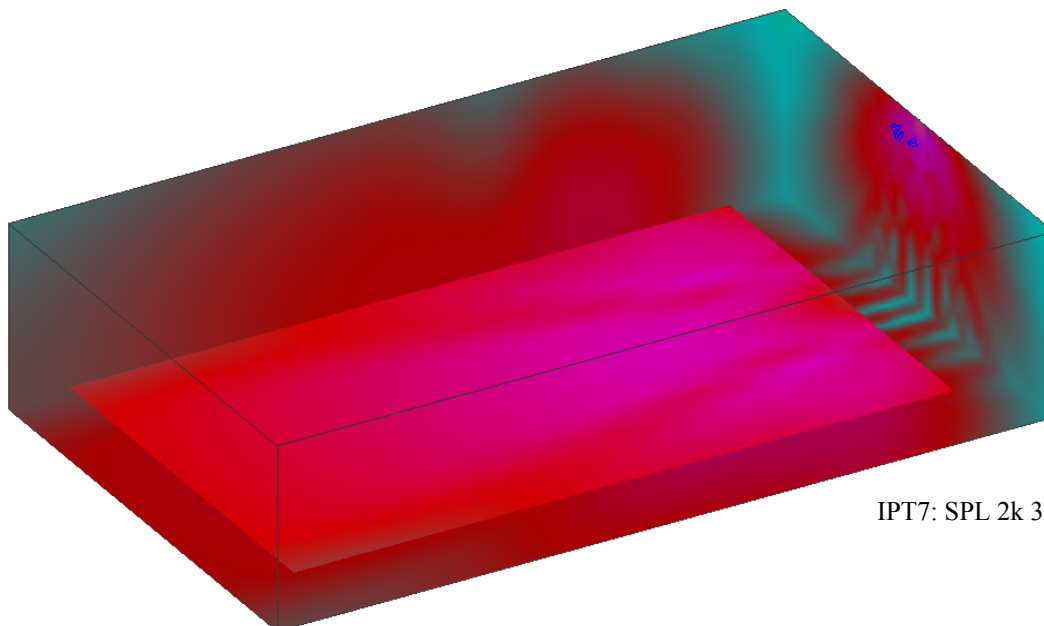

IPT7: SPL 2k 3D

RG8: Alcon 2k vs. **IPT8: Alcon 2k**

Finally, we see the results of our direct to reverberant energy ratio.

This is measured in Alcons, which is the percentage of consonants lost, which affects the intelligibility.

The lower the percentage lost the better.

Again, the **IPT** cluster shows the best results for this space.

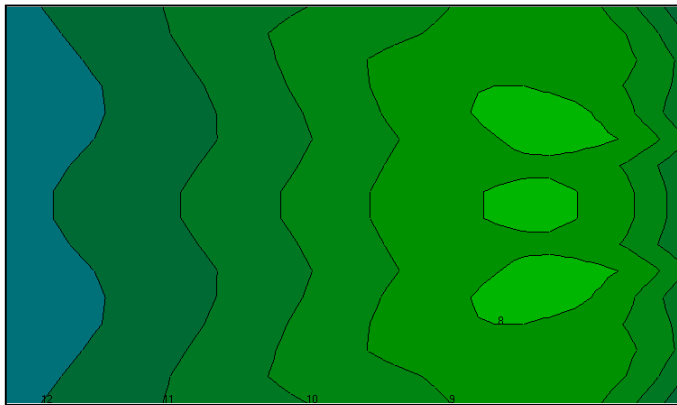

RG8: Alcon 2k

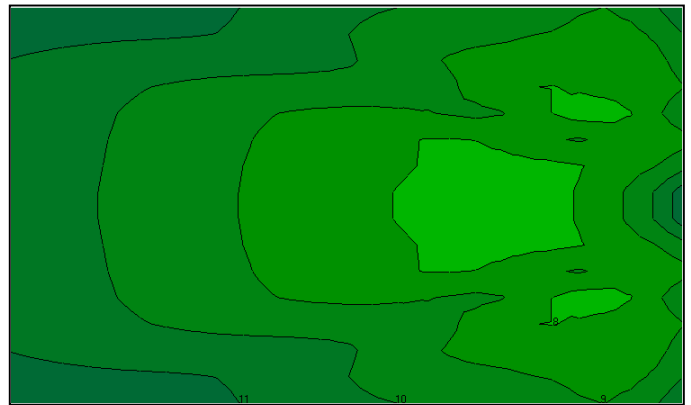

IPT8: Alcon 2k