

Polar[®] Focus

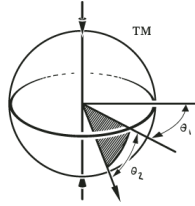

Audio Rigging Products

PY1-UJEXT-POST

PY1 Quick Disconnect Fitting with Line Array Extension Post

PY1 Quick Disconnect Fitting with PY1-UJEXT-POST allows an easy connection to Polar Focus[®] line array accessories.

Our Line Array Extension Post allows any cluster to be mounted up to 16 feet below the roof attachment point. The interior of the post has a 2 1/2" x 2 1/2" cavity, which allows speaker signal cable or amplifier power cable to be run through the post. This allows for a super clean installation.

The top of the PY1-UJEXT-POST assembly has a heavy duty rated U-joint. This allows the cluster to move laterally during a seismic event with minimal moments applied to the supporting roof beams.

Polar Focus Ultimate Line Array Rigging.

For more assistance, call our audio rigging consultants at (413) 586-4444.

See www.linearrayframes.com for pan control, roof attachment, OEM products, line array frames and manufacturer-specific rigging.



Figure 1.
**Polar Focus PY1 Quick Disconnect Fitting
with Line Array Extension Post**
*Allows any loudspeaker cluster to be mounted
up to 16 feet below the roof attachment point.*



Architectural Specification:

The rigging suspension device shall allow rigid bidirectional swing of the suspended load; suitable for seismic applications. The rigging suspension device shall be made of welded structural steel and grade 5 hardware.

The rigging suspension device shall have a design factor of 10:1 with a Working Load Limit of 1100 lbs.

The rigging suspension device shall be the Polar Focus PY1-UJEXT-POST.

Overall Length: 5.3" (135mm)
 Overall Height: See Table
 Overall Width: 4" (102mm)
 Weight: See Table
 Primary Material: Structural Steel
 Finish: Black Powder Coat
 Custom Powder Coat
 WLL: 1100 lbs (499 kg)
 Design Factor: 10:1

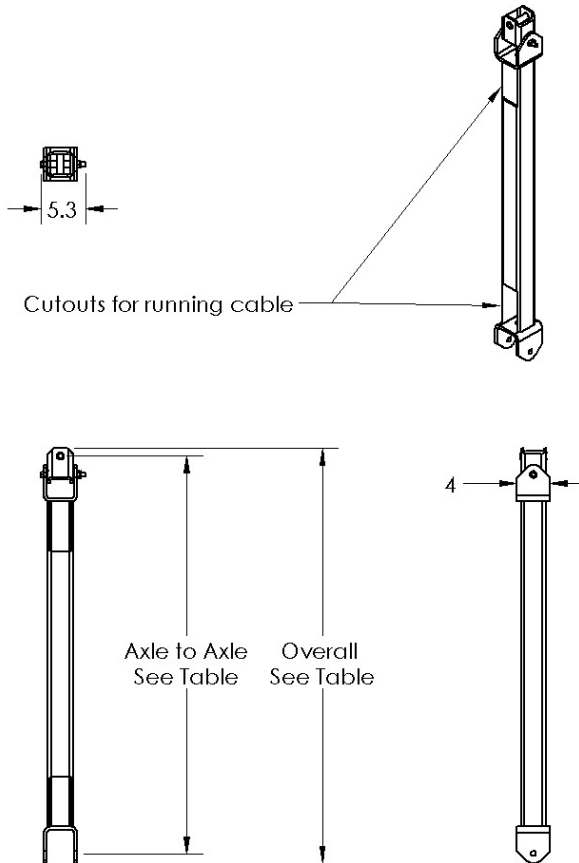

Table 1. Post Details

Part Name	Height: Overall (in)	Height: Axle to Axle (in)	Weight (lbs)
PY1-UJEXT-POST-2	26.19	24	15
PY1-UJEXT-POST-3	38.19	36	24
PY1-UJEXT-POST-4	50.19	48	33
PY1-UJEXT-POST-5	62.19	60	42
PY1-UJEXT-POST-6	74.19	72	51
PY1-UJEXT-POST-7	86.19	84	59
PY1-UJEXT-POST-8	98.19	96	68
PY1-UJEXT-POST-9	110.19	108	77
PY1-UJEXT-POST-10	122.19	120	86
PY1-UJEXT-POST-11	134.19	132	95
PY1-UJEXT-POST-12	146.19	144	103
PY1-UJEXT-POST-13	158.19	156	112
PY1-UJEXT-POST-14	170.19	168	121
PY1-UJEXT-POST-15	182.19	180	130
PY1-UJEXT-POST-16	194.19	192	139